



TOYODA GOSEI

December 25, 2023

## News Release

Toyota Gosei Co., Ltd.

Contact: Akemi Shimizu  
inquiry@mlist.toyoda-gosei.co.jp

### Toyota Gosei Pedestrian Protection Product Used by Chinese Automaker *In response to stricter automobile safety regulations in China*

Kiyosu, Japan, December 25, 2023: Toyota Gosei Co., Ltd.'s pop-up hood actuator, one of its safety system products, has been adopted for use on the EH7 from Chinese luxury automaker Hongqi.

Pop-up hood actuators instantaneously raise the hood in cases of collision with a pedestrian, lessening the impact on the pedestrian's head by creating a space between the hood and the rigid parts beneath it. Needs for such products are growing in China with the introduction of stricter pedestrian protection regulations.\*

Toyota Gosei recently reviewed the structure of its pop-up hood actuators and achieved greater compactness and lower costs by reducing the number of component parts by about 40 percent, without compromising the hood pop-up performance. The company has also established CAE technology related to hood lifting to better respond to Chinese automaker's development needs.

China is the world's largest automobile market, and competition is intensifying with the spread of electric vehicles and the emergence of new manufacturers. With the aim of being a supplier of choice to automakers there, Toyota Gosei will continue to offer products that meet customers' needs with its strengthened development capability in the country.

\* Toyota Gosei has supplied pop-up hood actuators to Japanese automakers in China since pedestrian collision safety assessments were introduced in 2018.

Hongqi EH7



Pop-up hood actuator

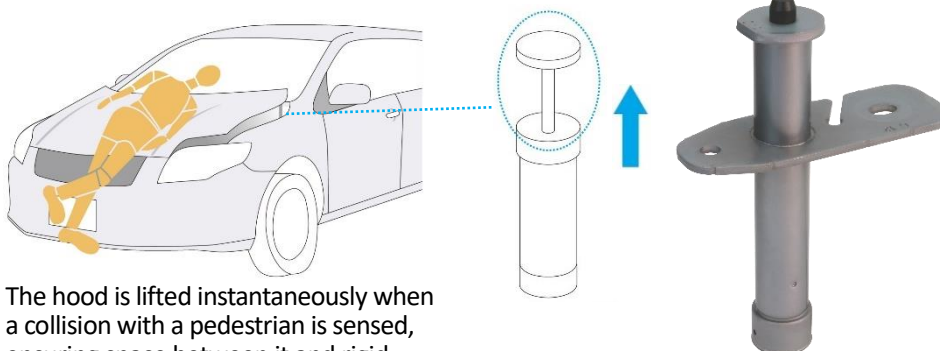

The hood is lifted instantaneously when a collision with a pedestrian is sensed, ensuring space between it and rigid components